

## Ramesh / Sita

Name	Ramesh	Sita
Sex	Male	Female
Date of Birth	14-07-1980 (Monday)	14-07-1985 (Sunday)
Time of Birth (Standard)	00:50:00 (Ishta-Kala 48:08:10 Ghatis)	00:50:00 (Ishta-Kala 48:08:23 Ghatis)
Time Zone/Country	India	India
Birth Place	Delhi	Delhi
Latitude	028:39 North	028:39 North
Longitude	077:13 East	077:13 East
Standard Longitude	082:30 East	082:30 East
Local Time Correction	-00:21:08	-00:21:08
War/Summer Time Corr.	+00:00:00	+00:00:00
Local Birth Time	00:28:52	00:28:52
Siderial Time	19:56:08	19:55:18
Sun Rise (Local)	05:13:36	05:13:31
Sun Set (Local)	18:53:48	18:53:52
Sun Rise (Standard)	05:34:44	05:34:39
Sun Set (Standard)	19:14:56	19:15:00
Tithi	Dvitiya	Ekadashi
Paksh	Shukla	Krishna
Shalivan Shak Samvat	1901-1902	1906-1907
Vikram Samvat	2036-2037	2041-2042
Yog	Vajra	Gand
Ayanamsa (N.C.Lahiri)	23:35:05	23:39:16
Sun Sign (Sayan)	Cancer	Cancer
Lagna-Lagna Lord	Aries-Mars	Aries-Mars
Rashi-Rashi Lord	Cancer-Moon	Taurus-Venus
Nakshatra-Charan	Pushya-4	Kritika-4
NakshatraLord	Saturn	Sun

### -=[ Ghat Chakra ]=-

Rashi	Cancer	Taurus
Month	Paush	Magh
Tithi	2 7 12	5 10 15
Day	Wednesday	Saturday
Nakshatra	Anuradha	Hast
Yog	Vyaghata	Sukmi
Karan	Naag	Shakuni
Prahar	1	4
Moon	2	4
Stri-Chandra	9	8

### -=[ Avkahda Chakra ]=-

Varna	Brahmin	Vaishya
Hansak	Vaari	Bhoomi
Vashya	Jalchar	Chatushpad
Nakshatra	Pushya	Kritika
Charan	4	4
Varg	Swan	Garud
Akshar	Da (Dalada)	A (Ekta)
Yoni	Aries	Aries
Gana	Dev	Raakshas
Yunja	Madhya	Purva
Nadi	Madhya	Antya
Ayan	Dakshin	Dakshin
Gool	Dakshin	Dakshin
Ritu	Varsha	Varsha

**Nirayana Planetary Longitudes**

Planet	Rashi-Lord	Degrees	Nakshatra-Pad	Rashi-Lord	Degrees	Nakshatra-Pad
Asc	Arie-Mar	16:06:13	Bharni-1	Arie-Mar	15:46:16	Bharni-1
Sun	Gemi-Mer	27:56:43	Punarvasu-3	Gemi-Mer	27:40:38	Punarvasu-3
Mon	Canc-Mon	16:11:01	Pushya-4	Taur-Ven	08:49:29	Kritika-4
Mar	Virg-Mer	08:09:11Dir.	Uttara Phalguni-4	Gemi-Mer	28:59:07Dir.	Punarvasu-3
Mer	Gemi-Mer	24:44:49Ret.	Punarvasu-2	Canc-Mon	24:13:08Dir.	Ashlesha-3
Jup	Leo-Sun	14:36:15Dir.	Purva Phalguni-1	Capr-Sat	21:04:31Ret.	Shravan-4
Ven	Taur-Ven	23:22:11Dir.	Mrig-1	Taur-Ven	14:27:06Dir.	Rohini-2
Sat	Leo-Sun	28:50:33Dir.	Uttara Phalguni-1	Libr-Ven	27:57:31Ret.	Vishakha-3
Rah	Canc-Mon	26:36:05Ret.	Ashlesha-3	Arie-Mar	22:27:18Ret.	Bharni-3
Ket	Capr-Sat	26:36:05Ret.	Dhanishtha-1	Libr-Ven	22:27:18Ret.	Vishakha-1

Positions of Rahu and Ketu are True.

**Lagna Chart**

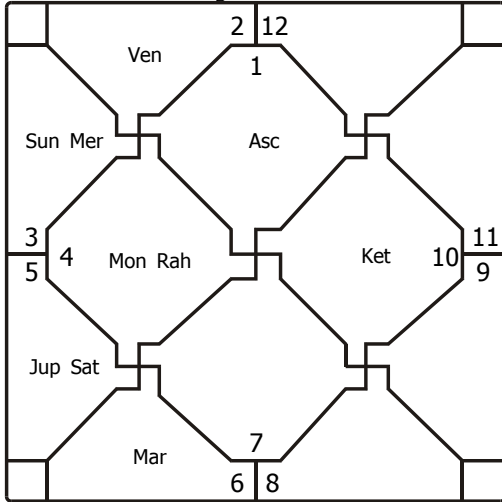

**Lagna Chart**

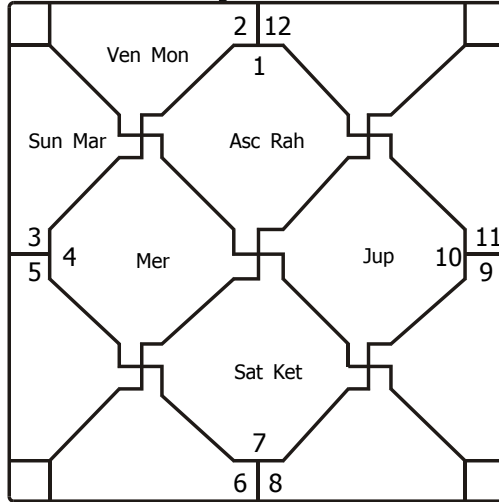

**Nirayana Bhaav Chalit**

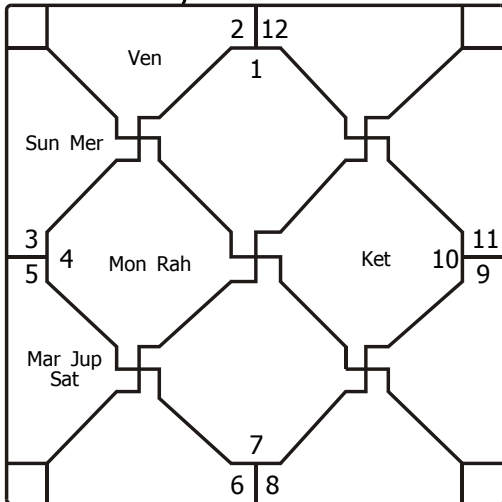

**Nirayana Bhaav Chalit**

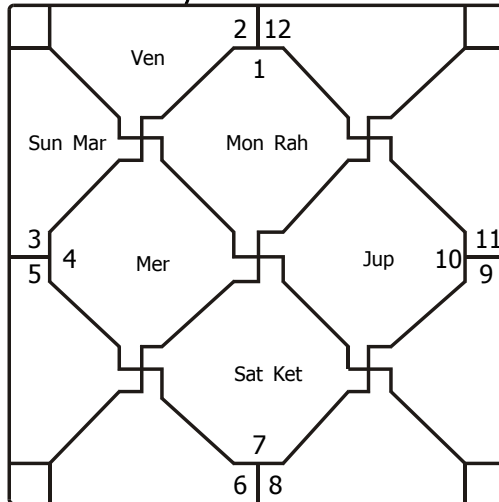

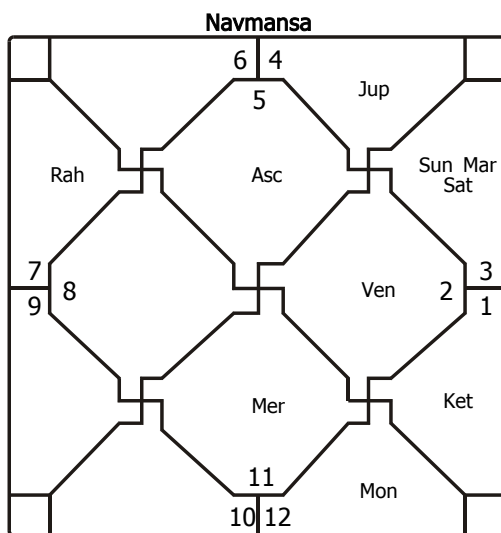
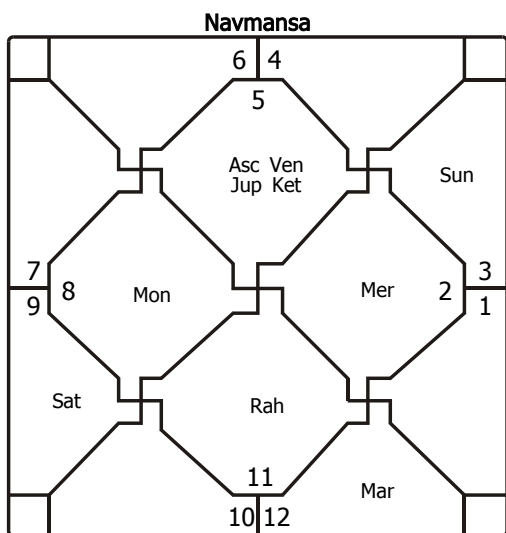
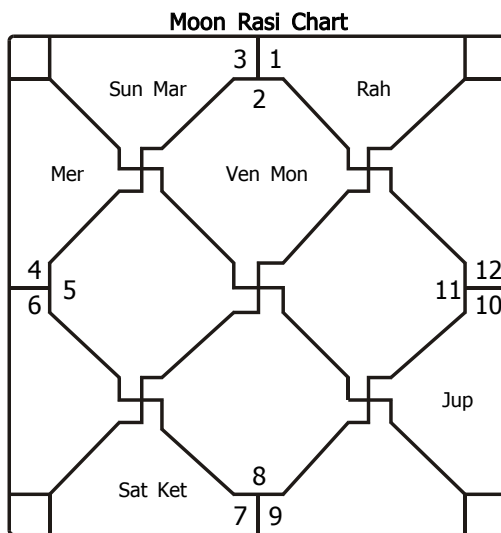
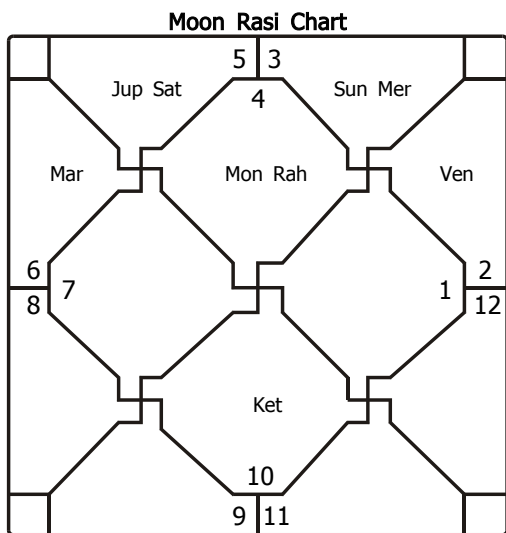
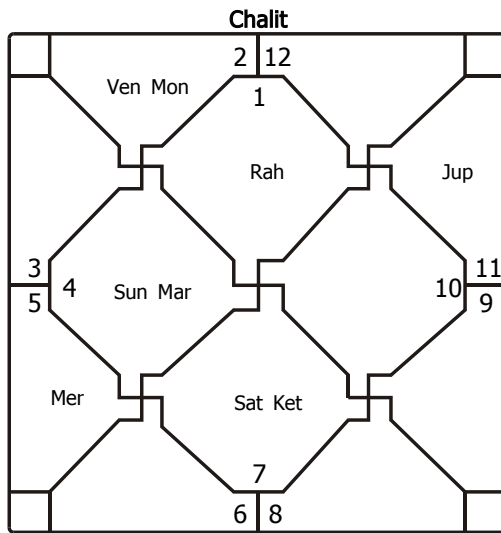
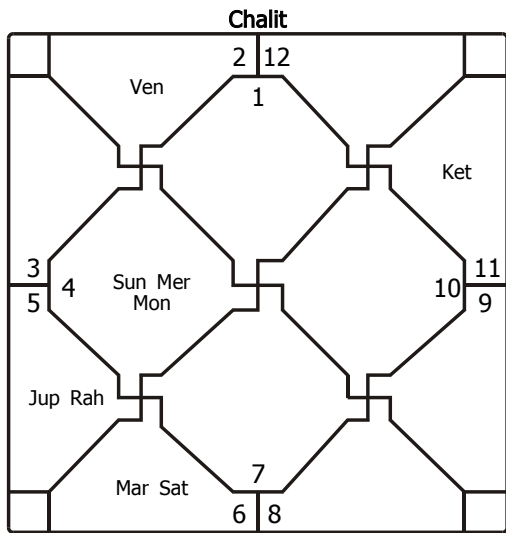

Match Consideration

- Varna                      *Varna indicates ego development between the partners.*  
10 points in the compatibility chart of the boy and the girl indicate excellent adjustment. The wife will treat the husband with respect and the husband will treat the wife with affection.
- Vashya                      *Vashya indicates the intensity of mutual attraction and affection between the couple.*  
10 points in the compatibility chart of the boy and the girl indicate very normal results. Nothing exceptional.
- Tara/Din                      *Tara/Din indicates the health and well-being of the couple.*  
15 points in the compatibility chart of the boy and the girl indicate health of the partner may cause concern from time-to-time.
- Yoni                              *Yoni indicates biological compatibility and satisfaction.*  
4 points in the compatibility chart of the boy and the girl indicate excellent compatibility and perfect satisfaction.
- Graha Maitri                      *Graha Maitri indicates outlook, objective, intellectual level and spiritual plane of existence.*  
5 points in the compatibility chart of the boy and the girl indicate major differences in objective and outlook. The partners will live in different intellectual and spiritual levels, and will less likely be sensitive to the other partner's feelings.
- Gana                              *Gana indicates the temperamental characteristics.*  
0 points in the compatibility chart of the boy and the girl indicate possibility of frequent temperamental clashes.
- Bhaktut                              *Bhaktut indicates growth of the family, family-welfare, etc.*  
7 points in the compatibility chart of the boy and the girl indicate excellent in respect of prospect of progeny and the general well-being of the family. One of the children may become a source of pride and joy to the family.
- Nadi                              *Nadi signifies the health(outward physique) and constitution(internal metabolism).*  
8 points in the compatibility chart of the boy and the girl indicate since Nadi Koota agreement exists between the two charts, the couple will enjoy good health and sound physique.

*Astrological compatibility consideration is not only a mere ancestral practice but is a way to get the knowledge regarding the nature, features, love and the social communication features of the people. Unless and until a compatibility is found between the two persons they can't hold a life-long relationship happily. Since it is a very difficult task to get the accurate knowledge of the person's nature etc. before a marriage (or a long-term relationship), the proven science of Astrology can definitely help the two lives a great deal.*

Group	Boy	Match Chart	Obtained	Max.Points
Varna	Brahmin	Vaishya	1	1
Vashya	Keet	Chatushpad	1	2
Tara/Din	Vipat	Maitra	1.5	3
Yoni	Aries	Aries	4	4
Graha Maitri	Moon	Venus	0.5	5
Gana	Dev	Raakshas	0	6
Bhakut	Cancer	Taurus	7	7
Nadi	Madhya	Antya	8	8
<b>Total Points</b>			<b>23</b>	<b>36</b>

#### Match Chart Consideration

The score of compatibility points is above-average. This is indicative of over-all favourable results in respect of matters pertaining to married life in general, and good harmony in married life is assured. Marriage between the prospective pair is recommended. Normally a match with 18 or more points is considered good.

#### Manglik Consideration

The boy and the girl are not Manglik, hence there's no problem in match from the point of view of Manglik Dosha.